

A Cryogenic Half-Wave Plate Module to Measure Polarization at Multiple FIR Passbands

Timothy S. Rennick*, John E. Vaillancourt**, Roger H. Hildebrand⁺, and Stephen J. Heimsath*

Abstract

One of the key components in a far-infrared polarimeter that is being designed at The University of Chicago is a locally-powered half-wave plate module. This compact, lightweight, and reliable module will operate at cryogenic temperatures, rotating a half-wave plate about its axis within the optical path. By doing so, polarization measurements can be made. Further, by utilizing multiple half-wave plate modules within the polarimeter, multiple wavelengths or passbands can be studied. In this paper, we describe the design and performance of a relatively inexpensive prototype module that was assembled and tested successfully, outline the difficulties that had to be overcome, and recommend improvements to future modules. This effort now lays some of the groundwork for a next-generation polarimeter for far-infrared astronomy.

Introduction

Instruments designed for far-infrared (FIR) and submillimeter astronomy generally operate with the detectors and most of the optical elements at cryogenic temperature. When the design calls for inserting any of several lenses or filters into the optical path, there must be suitable actuators, bearings, and sensors for the moving parts. The actuators have usually consisted of external, room temperature, motors connected to the moving parts by insulating shafts passing through vacuum seals and working their way through tight spaces at times via right angle gearing to the cold parts. This approach has been workable for relatively simple instruments, but has become increasingly difficult as the instruments have become more complex.

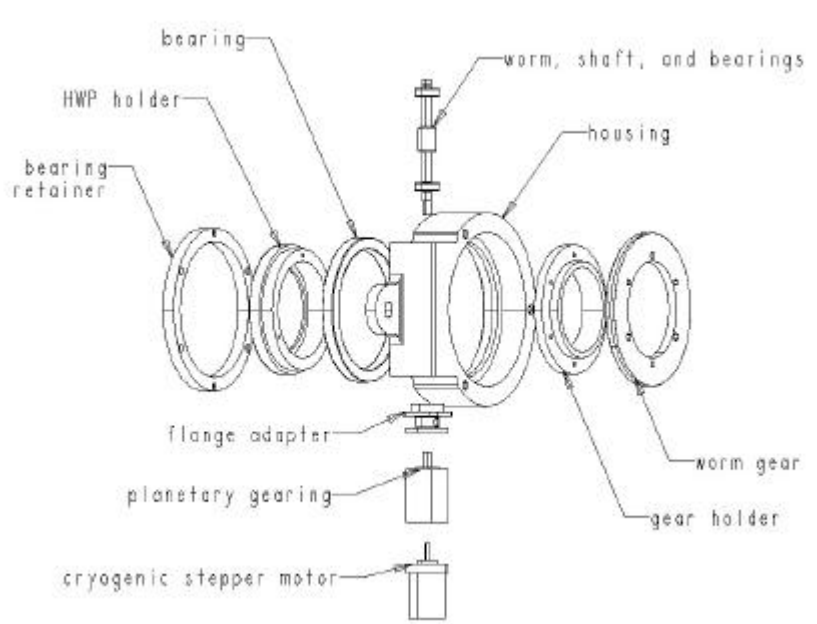

Figure 1. Exploded view of HWP module

* The University of Chicago, University of Chicago Engineering Center, Chicago, IL.

** The University of Chicago, Dept. of Astronomy & Astrophysics, Chicago, IL; now with the University of Wisconsin, Dept. of Physics, Madison, WI.

⁺ The University of Chicago, Dept. of Physics, Dept. of Astronomy & Astrophysics, Enrico Fermi Institute, Chicago, IL.

At The University of Chicago, we are designing a far-infrared polarimeter to cover a wide range of wavelengths. The telescope that this polarimeter is intended to work in conjunction with is the Stratospheric Observatory for Infrared Astronomy (SOFIA) (Ref. 1). At the heart of the polarimeter, a rotating carousel-style stage will be used to put any one of five polarizing half-wave plates into the optical path. It must then be possible to rotate the selected half-wave plate (HWP) about its own axis to conduct the polarization studies. It does not appear practical to produce the required HWP rotation on a carousel-style stage using shafts from external motors. We have therefore carried out investigations on a prototype module in which a cryogenic motor is located immediately adjacent to the rotating HWP, eliminating the need for protruding shafts and external motors. This prototype module is composed of the HWP holder with its bearing, motor, gearing, and housing (shown in Figure 1) and is designed to hold a lens, a spectral filter, and a pupil stop attached to the housing. The module, with its accompanying optical elements, is designed to be easily replaceable, allowing different options for wavelengths and magnification.

The final instrument will have five such modules on a carousel-style stage. Such an arrangement envisioned for measuring multiple FIR passbands is shown in Figure 2. For a sense of scale, each HWP has a clear aperture of approximately 75 mm diameter.

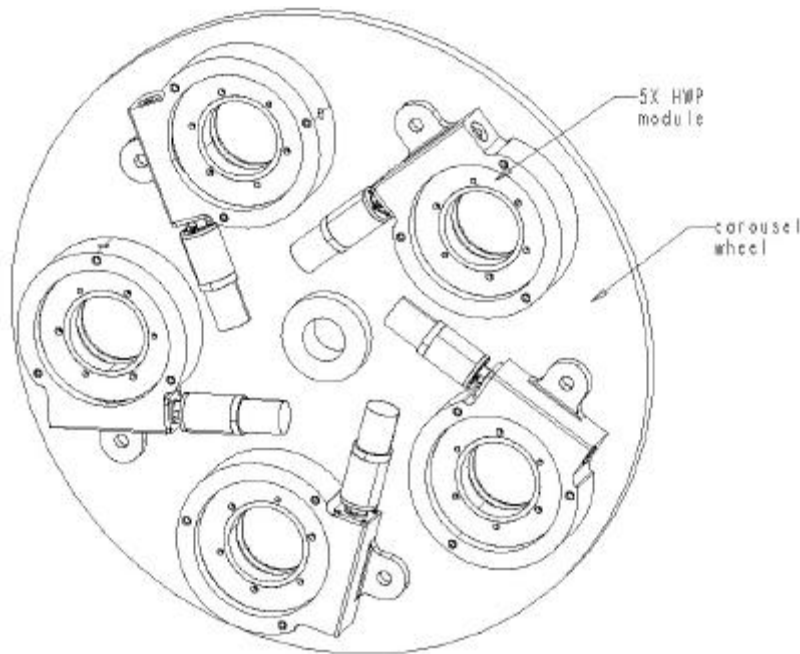

Figure 2. Carousel-style stage supporting multiple HWP modules

In this paper, we describe the design and performance of the prototype HWP module, outline the difficulties that had to be overcome, and recommend improvements to future modules.

Module Design

Specific objectives of the design effort were to produce a prototype HWP module that was compact, lightweight, relatively inexpensive, and reliable, particularly since it would not be accessible during operation. The module had to operate at both room temperature and near the temperature of liquid helium (near 4 K). Additionally, a means of sensing the rotational position of the half-wave plate had to be

included. It was desired that such position information be independent of counting step commands sent to the cryogenic motor. During normal operation, the HWP will be stepped once a minute in 30-degree increments that take approximately 5 seconds, corresponding to a duty cycle of approximately 8%. Another requirement was that the motor heat, at the normal duty cycle, should not increase the boil-off rate of the liquid helium reservoir significantly and thereby impact observation time.

Cryogenic Motor

Price and recommendations were major considerations in the selection of the cryogenic motor. In addition, the particular motor selected had to be small, lightweight, run on relatively low power, but yet have sufficient torque, and be easily controllable. A general design envelope defined the extent of the motor size. Simple computations were performed to assess the torque requirements based upon HWP inertia. These computations accounted for accelerating the small rotating mass of the HWP and its holder. The results indicated very low values of motor torque were needed. It was anticipated, though, that friction in the gearing and bearing, which could not be reliably predicted, would be the major motor load. To boost the output of the motor, an integral planetary gear unit, with a ratio of 25:1, was selected. Both the motor and planetary gearing came as one unit, fully wired, internally lubricated, and ready to run.

HWP Bearing

A low profile bearing was chosen to support the HWP in the module because of space limitations. Further, the eventual implementation of this HWP module would be on board an aircraft, exposed to a flight environment. To minimize jitter of the HWP and possible microphonic effects picked up in the instrument's detectors, a precision X-bearing (i.e. four point contact) was selected. With a bearing of this type in a cryogenic application, it was critical that the material of the races match that of the ball bearings. Stainless steel alloy 440C was selected for both.

Gearing

Since the HWP was at the center of the module and required a clear aperture, the motor that drove it had to be offset. This required gearing, besides the planetary gear unit, to transfer the motion. A worm gear arrangement was chosen, even though this type of gearing suffers from large amounts of friction, because it was conducive to the space available and had a relatively high gear ratio to further boost the output torque and step count. For example, the stepper motor is 200 steps/rev; the planetary gear ratio is 25:1; the worm gear ratio is 25:1. Thus, the theoretical step count for a complete revolution is $200 \times 25 \times 25 = 125,000$ steps. The rotational accuracy desired for the polarization studies was ± 1 degree or better, and this was thought to be easily achievable.

Magneto-resistive Position Sensor

To independently sense the HWP position, small cryogenic sensors were investigated. A magneto-resistive sensor from Infineon Technologies was recommended and samples were provided. The sensor was a differential magneto-resistive sensor (type FP 212 L 100) and consisted of two series coupled InSb/NiSb semiconductor magneto-resistors, whose resistance could be magnetically controlled, mounted on an insulated ferrite substrate (Ref. 2). A permanent magnet, which supplied a biasing magnetic field, was fixed to the base of the sensor. The entire sensor was contained in a plastic housing and had three connecting terminals that were subsequently soldered to a small circuit board for mounting and wiring. The basic room temperature resistance of the sensor was $2 \times 100 \text{ } \Omega$. These particular sensors were selected and had been tested successfully on a related project to a temperature of 12 K, which gave us some confidence that the sensors would operate at the temperature that we desired. Not only could these sensors detect position, but because there were two magneto-resistors, the device as a whole could sense direction; although, we did not choose to use this capability in our prototype testing. The sensor was quite small at about 6 mm x 3 mm and 0.35g, and it was relatively easy to implement. A 5 V potential was continuously applied, and output signals were on the order of tens to hundreds of millivolts. A small electronic circuit was created to amplify the output signal, and a commercial off-the-shelf digital counter was used to record movement of the HWP. Since the precise HWP location information was not necessary for the prototype testing, sampling of the HWP position was conducted only once per revolution by attaching a small ferromagnetic chip on the rotating HWP holder to actuate the stationary sensor (by altering the magnetic field of the permanent biasing magnet and eliciting a response from the

magnetoresistors) each time it passed. Future implementation of this sensor will likely incorporate more exact information on HWP position, including any incremental amount of rotation and possibly a sense of direction.

Aluminum Housing

With many dissimilar materials used in the module, there were obvious concerns over interference and binding due to shrinkage as the module was cooled to its eventual operating temperature. After considering several designs, it was decided that the best approach was to accommodate the shrinkage within the assembly tolerances, particularly since the dimensions involved were not all that great and shrinkage was mostly concentric about the HWP. Taking this approach had the disadvantage of creating a “sloppier” mechanism than desired at room temperature. However, by surrounding the stainless steel HWP bearing with an elastomeric o-ring to center it and fill the purposely-open gap, the module was able to operate satisfactorily at both room temperature and at cryogenic temperatures. The size of the o-ring (nominal 1.6 mm diameter) and depth of the groove in the housing were selected so that the o-ring just contacted the outer bearing race at room temperature and then experienced roughly 10% diametral squeeze upon cooling.

A listing of all components within the assembled module is shown in Table 1. As can be seen, many of the components were commercially available, generally reducing cost associated with the prototype. The total mass of the assembled module was 851g, an amount that is probably more than desired for the future flight design.

Table 1. Components of HWP module

Component	Supplier	Part Number	Approx. Cost (\$US)	Material
Stepper Motor	Phytron, Inc.	VSS 19.200.0.6	4400	Stainless steel housing
Planetary Gearing	Phytron, Inc.	VGPL 22/25-UHVC-X	<i>a</i>	Stainless steel housing
HWP Bearing	Kaydon Corporation	Reali-Slim SA025XSO	380	Stainless 440C
Precision Worm	W. M. Berg, Inc.	W32S-3F	66	Stainless 303
Precision Worm Gear	W. M. Berg, Inc.	W32B30-F100	50	Bronze Alloy 464
Magnetoresistive Sensor	Infineon Technologies	FP 212L-100	<i>b</i> (580)	Plastic housing
Housing	Univ. of Chicago	NA	~ 5000	Aluminum 2024
Shaft	Univ. of Chicago	NA	<i>c</i>	Stainless 303
Shaft Bearings	W. M. Berg, Inc.	B1-26-Q3 ABEC3	18	Stainless 440C
Shaft Coupling	McMaster-Carr	59925K88	90	Nickel
Flange Adapter	Univ. of Chicago	NA	<i>c</i>	Stainless 303
HWP Retainer	Univ. of Chicago	NA	<i>c</i>	Aluminum 2024
HWP Holder	Univ. of Chicago	NA	<i>c</i>	Stainless 440C
Gear Retainer	Univ. of Chicago	NA	<i>c</i>	Stainless 440C

a – included in cost of motor

b – sensor donated by Infineon Technologies, cost in parenthesis associated with circuit board and digital counter

c – included in cost of housing

Figure 3 shows a front and back view of the prototype module and sensor once assembled and attached to a bracket for testing.

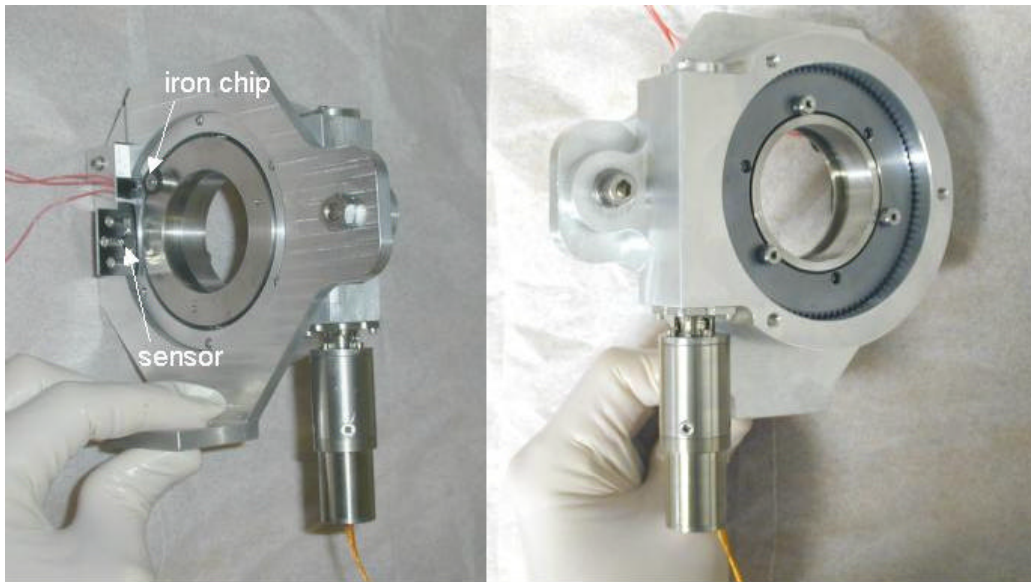

Figure 3. Front and back view of prototype module with magnetoresistive sensor

In addition, the module was tested first without and then with a modified tungsten disulfide dry lubricant, Dicronite[®] DL-5, applied to the worm gearing in hopes of reducing gear friction and lessening the motor load and, thus, heat produced by the module. This lubricant was selected primarily because of its low cost, availability in the Chicago area, and its advertised characteristics that appeared to match our needs. Because of time and cost concerns, no testing or extensive investigation was conducted to screen various lubricants and determine the most effective. This would be worthwhile, though, in the future.

Module Testing

Testing of the prototype HWP module was conducted in a cryostat that was originally designed as a far-infrared polarimeter for use on the Kuiper Airborne Observatory (Ref. 3). The cryostat has a dual stage He³ refrigerator system capable of reaching temperatures as low as 300 mK. However, the He³ system was not used in our tests, and only cooling from the liquid helium (LHe) reservoir was used to obtain temperatures near 4 K. The cryostat has two radiation shields at LHe temperature, one at liquid nitrogen (LN₂) temperature (77 K), and an outer vacuum shell at room temperature.

The magnetoresistive sensor was wired using low thermal conductivity stainless-steel wire inside the cryostat. The high current needs of the cryogenic motor (specified at 0.6 A per phase), however, precluded the use of low conductivity wire. Therefore, copper wire was used inside the cryostat to supply power to the motor. By observing liquid helium boil-off rates, we estimated the extra heat conducted from room temperature to the 4 K surface along these 4 copper motor wires (2 per phase) nearly doubled the heat reaching the 4 K surface. This was an initial concern when the idea to relocate the motor inside the cryostat was conceived. As such, heat loads on the 4 K surface were a major focus of the testing. In the future, more attention will be focused on heat-sinking the motor leads to the radiation shields and possibly taking advantage of a vapor-cooling effect by routing the leads in the vicinity of venting helium gas.

Goals of HWP Module Testing

The goals of the module tests were two-fold. First, and most importantly, would the concept of a locally-powered half-wave plate function at cryogenic temperatures and would it do so repeatedly and reliably? Second, what amount of power/heat would be dissipated at the 4 K stage while the module was operating?

Our astronomy application requires rotating the HWP by 30 degrees in about 5 seconds, the equivalent of 1 rpm. Given that one revolution of the HWP is approximately 125,000 motor steps this would necessitate a nominal stepping frequency of about 2 kHz. However, accounting for the additional time to start and stop the motor, the 2 rpm (4 kHz) stepping rate seemed to result in a time closer to the required 5 seconds for a 30-degree increment.

An unexpected obstacle was encountered following initial assembly and during the module's first stages of testing. This obstacle required lengthy troubleshooting to overcome. The module would operate properly at room temperature, but not at cryogenic temperatures even though the design had been carefully reviewed. Through a process of elimination, possible culprits such as the stepper motor, clearances on the aluminum housing, and even the magnetoresistive sensor were eliminated. It was determined that the HWP bearing was seizing due to either warpage of the bearing races or slight material variations in the stainless steel used throughout the bearing. The bearing supplier worked with us to incrementally change the bearing's diametral clearance by reducing the ball size until unrestricted rotation was observed while submerged in a bath of liquid nitrogen. Apparently, the bearing's level of precision was too close to withstand the large change in temperature. Once this obstacle was overcome, further testing proceeded smoothly.

Testing in the bath of liquid nitrogen proved to be a quick, low cost approach to checking cryogenic operation of the mechanism, particularly when troubleshooting the seized bearing. Fiberglass (G10) rods were used to manipulate the components in the bath, and the temperature of the component could be inferred by monitoring the boiling rate. In fact, at one point, the entire module (minus motor and sensor) was completely submerged in a bath of liquid nitrogen and verified to spin freely.

Further testing was performed once the motor was attached to the gearing and aluminum housing.

Minimum Motor Current

The motor specifications call for running the motor at a nominal current of 0.6 A per phase. At each temperature (room, nitrogen, and helium) we measured the minimum current required to turn the HWP module. At room temperature, the system spun freely in both directions and at both the 1 and 2 rpm speeds with a minimum current of 0.2 A. At liquid nitrogen and liquid helium temperatures the system required 0.2 A to run at 1 rpm, and 0.3 A to run at 2 rpm. Fundamentally this makes sense: More power is required to cover an equal distance in a shorter period of time. With more accurate instrumentation, we may have seen this effect at room temperature as well.

At room temperature, the resistance across the motor coils was measured to be $\sim 3 \text{ } \Omega$; when cooled with liquid nitrogen the resistance was $1 \text{ } \Omega$; and at liquid helium it was $0.6 \text{ } \Omega$. Therefore, given the minimum currents found previously, the motor should theoretically be able to operate at 2 rpm dissipating $(0.3 \text{ A})^2 \times 0.6 \text{ } \Omega = 54 \text{ mW}$ of power per phase (108 mW total). At 1 rpm, this value would drop to 48 mW total. A large fraction of this power would be dissipated through heating of the motor coils.

Endurance Testing

Successful endurance tests were run at both liquid nitrogen and liquid helium temperatures. These tests were conducted with a motor current of 0.3 A at 2 rpm. The module was rotated through 720 30-degree steps of the HWP with five seconds of rest between each step. Additionally, tests were conducted with the module continually operating. These particular tests were conducted at liquid helium temperature and dissipated a significant amount of heat into the reservoir of liquid helium. As a result, the flow rate out of the venting helium gas that was liberated increased significantly. Additionally, the motor coil resistance gradually increased from $0.6 \text{ } \Omega$ to $0.8 \text{ } \Omega$, indicating that current was warming the motor. This type of test was conducted more as a measure of the module reliability, because such operation would not be normally experienced.

Dry Lubricant

In an attempt to lower the heat dissipated by the motor a dry lubricant, Dicronite[®] DL-5, was applied to the worm and worm gear. The minimum current required to turn the HWP at liquid helium temperature was

again found to be 0.3 A at 2 rpm and 0.2 A at 1 rpm. The amount of heat reaching the helium surface due to the motor and HWP module was measured by examining the boil-off rate of the liquid helium both before and after applying the dry lubricant. The motor was allowed to run continuously at 2 rpm and 0.3 A per phase for 20 minutes. The measured change in helium boil-off rate as a function of time is shown in Figure 4. (The heat is also estimated in mW, using 2.6 J/ml for the heat of vaporization of helium.) As can be seen, there appears to be little difference. However, had the module run longer until equilibrium was achieved, a more significant difference might have been apparent. For the application at hand, though, with a relatively low duty cycle under normal operation, the Dicronite[®] DL-5 lubricant will not be of great benefit.

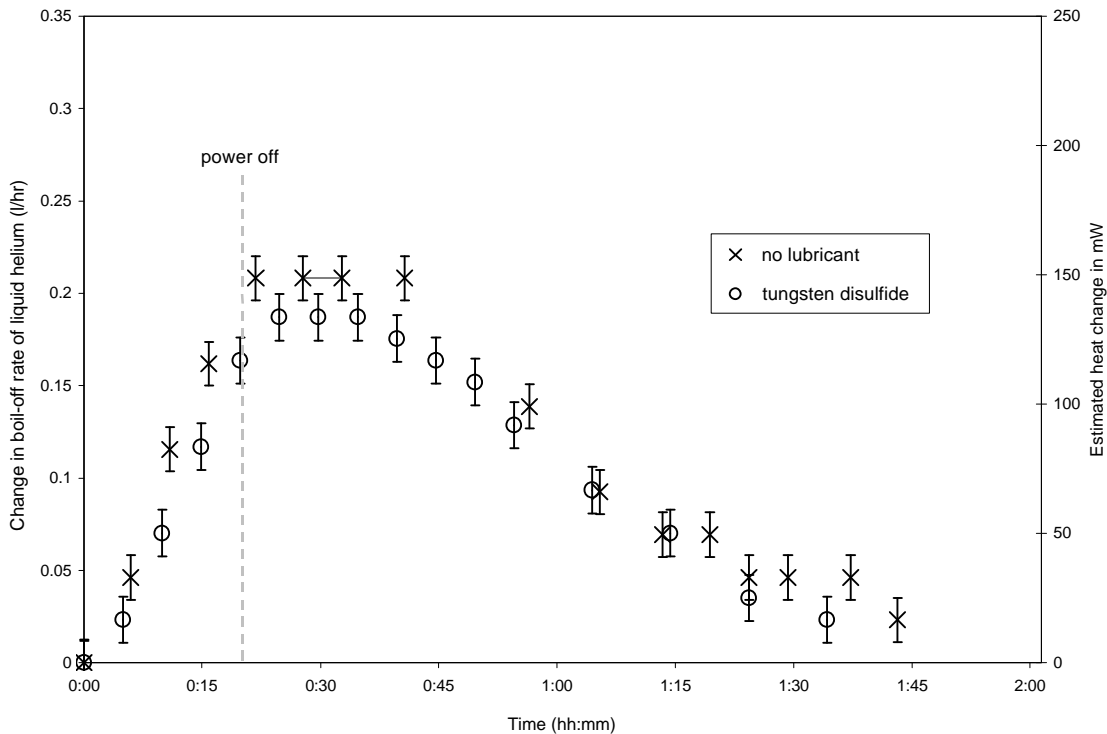

Figure 4. Effect of Dicronite[®] DL-5 lubricant on worm gear

Duty Cycle Variations

With the lubricant applied to the worm gearing, another series of heat load tests were performed to determine the expected heat load from continuous rotation of the HWP, from stepped rotation of the HWP, and from the magnetoresistive sensor alone. For each scenario, the boil-off rate of liquid helium was allowed to come to equilibrium. Figure 5 shows the extra heat on the 4 K surface for each scenario in terms of boil-off rate and estimated milliwatts. In Table 2, the measured equilibrium values are summarized.

As can be seen, the cryogenic motor when run continuously produces more heat than would be predicted from input electrical power (recall the 108 mW total previously computed). Obviously, from Figure 5, the measured heat load from the motor is nearly twice that expected. Since input power should theoretically equal the motor's output plus losses, this surplus heating is not clearly identifiable. Creating a more efficient mechanism could certainly reduce this heating some. However, utilizing a reduced duty cycle seems to be the most effective means of limiting heat loads from the cryogenic motor and rotation of the HWP. Fortunately, for the intended polarimeter, this is possible.

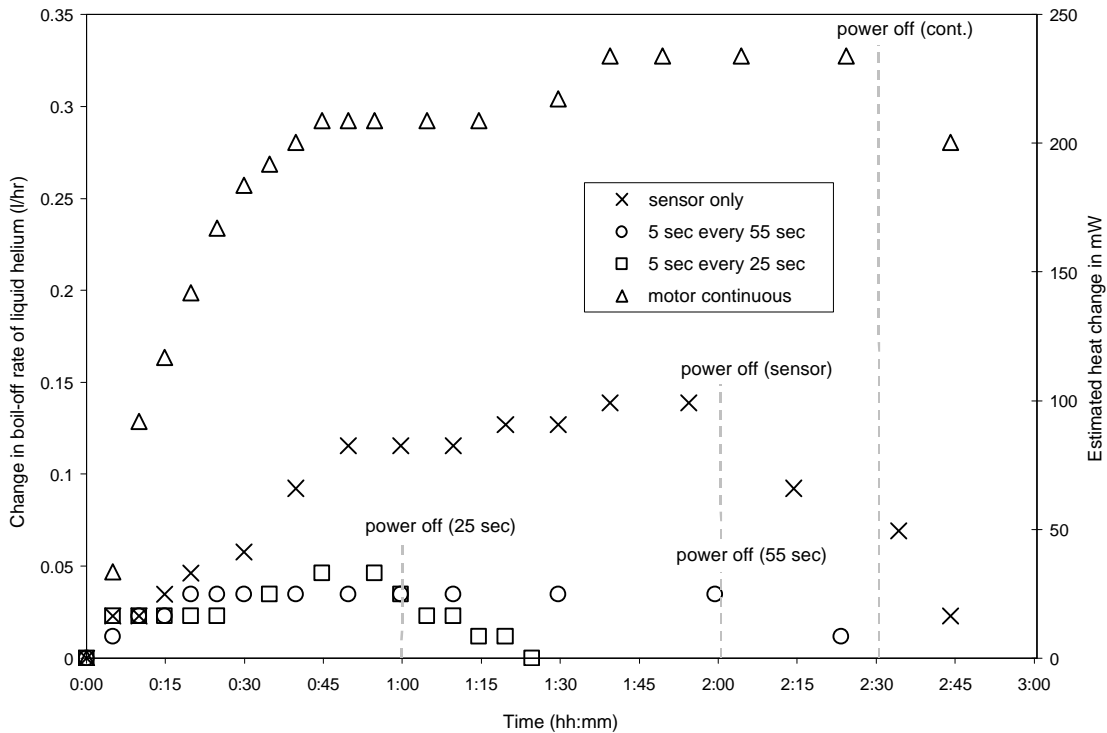

Figure 5. Effect of variations in duty cycle and sensor heat load

Table 2. Equilibrium heat loads

	LHe boil-off (l/hr)	Estimated heat (mW)	% increase above baseline
No electronics baseline	0.37	267	-
Magnetoresistive sensor alone	0.14	101	38%
Continuous motor w/o sensor	0.32	231	86%
Motor 5 sec every 55 sec w/o sensor	0.03	22	8%
Motor 5 sec every 25 sec w/o sensor	0.05	36	14%

Sensor Heat Load

In Figure 5, it can also be seen that the magnetoresistive sensor adds a large amount of heat to the 4 K surface relative to normal operation of the cryogenic motor. The magnetoresistive sensor consists of two 100 Ω resistors in series at 5 V potential. It should therefore dissipate about 125 mW of power at room temperature; using a measured resistance of 0.34 Ω at LHe temperature, it should dissipate 73 mW of power. This correlates reasonably well with the results shown in the graph and table, giving a sense of the accuracy of the measurements made. Because of the relatively high heat dissipation by the sensor, future module design and sensor implementation may require either a different sensing device or necessitate a duty cycle consistent with the motor.

Conclusion

Some conclusions that can be drawn from this work are:

- ?? Testing of the prototype HWP module was successful, exhibiting confidence in a new approach to measure polarization at multiple FIR passbands.
- ?? Selection of a bearing for cryogenic application is a critical step. A precision X-bearing apparently over constrained and bound the mechanism when significant cooling occurred, necessitating looser diametral clearance between the balls and races.
- ?? Centering the HWP bearing with an elastomeric o-ring allowed both room temperature and cryogenic operation when dissimilar materials were present and tolerances factored in to account for shrinkage.
- ?? For the application at hand, with a relatively low duty cycle under normal operation, the Dicronite® DL-5 lubricant applied to the worm gearing will not be of great benefit.
- ?? The continuously energized Infineon magnetoresistive sensor heat load was higher than desired, indicating a need to investigate other sensing means or employ a low duty cycle on the sensor, similar to the motor, to reduce this heat load.
- ?? Future work will be focused upon reducing the module mass and lowering the heat load further.

The success of this small project now lays some of the groundwork for a next-generation polarimeter for far-infrared astronomy.

Acknowledgements

We would like to thank G. Kelderhouse and H. Krebs of The University of Chicago, A. Kepley of Case Western Reserve University, W. Lahmadi and J. Lagdam of Phytron, Inc., W. Tenbrink of Kaydon Corporation, and E. Shankland of Infineon Technologies. This work has been supported by NSF grant 9987441. J. Vaillancourt was supported by NASA Graduate Student Research Program grant NGT 5-63. A. Kepley was supported by NSF funding through the Center for Astrophysical Research in Antarctica (CARA) Research Experience for Undergraduates (REU) program.

References

1. Becklin, E. E. "Stratospheric Observatory for Infrared Astronomy (SOFIA)." Proceedings of the ESA Symposium *The Far Infrared And Submillimetre Universe* 15-17 April 1997, Grenoble, France, ESA SP-401 (August 1997), 201-206.
2. Differential Magnetoresistive Sensor FP 212 L 100, Data Sheet 1999-04-01, Infineon Technologies.
3. Platt, S. R., R. H. Hildebrand, R. J. Pernic, J. A. Davidson and G. Novak. "100- μm Array Polarimeter from the Kuiper Airborne Observatory: Instrumentation, Techniques, and First Results." *Publications of the Astronomical Society of the Pacific*, 103 (November 1991), 1193-1210.

